

**Open-Frame Stepper Drives**

88-029135-01B

# **OFS350-DRI Microstep Driver Hardware Installation Guide**

Effective: April 2010

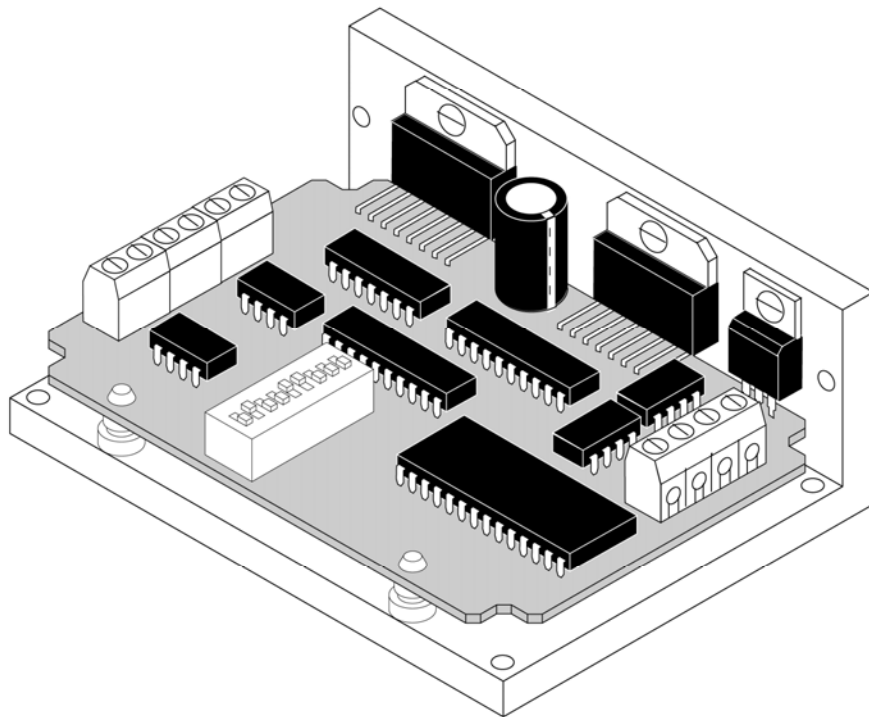

ENGINEERING **YOUR** SUCCESS.

# User Information



**Warning** — The OFS350 series step motor drivers are used to control electrical and mechanical components of motion control systems. You should test your motion system for safety under all potential conditions. Failure to do so can result in damage to equipment and/or serious injury to personnel.

The OFS350 series step motor drivers and the information in this guide are the proprietary property of Parker Hannifin Corporation or its licensors, and may not be copied, disclosed, or used for any purpose not expressly authorized by the owner thereof.

Since Parker Hannifin constantly strives to improve all of its products, we reserve the right to change this guide, and software and hardware mentioned therein, at any time without notice.

In no event will the provider of the equipment be liable for any incidental, consequential, or special damages of any kind or nature whatsoever, including but not limited to lost profits arising from or in any way connected with the use of the equipment or this guide.

© 2003-2008 Parker Hannifin Corporation  
All Rights Reserved

## Technical Assistance

Contact your local automation technology center (ATC) or distributor.

### North America and Asia

Parker Hannifin  
5500 Business Park Drive  
Rohnert Park, CA 94928  
Telephone: (800) 358-9070 or (707) 584-7558  
Fax: (707) 584-3793  
Email: [emn\\_support@parker.com](mailto:emn_support@parker.com)  
Internet: <http://www.parkermotion.com>

### Germany, Austria, Switzerland

Parker Hannifin  
Postfach: 77607-1720  
Robert-Bosch-Str. 22  
D-77656 Offenburg  
Telephone: +49 (0) 781 509-0  
Fax: +49 (0) 781 509-176  
Email: [sales.hauser@parker.com](mailto:sales.hauser@parker.com)  
Internet: <http://www.parker-emd.com>

### Europe (non-German speaking)

Parker Hannifin plc  
Electromechanical Automation, Europe  
Arena Business Centre  
Holy Rood Close  
Poole  
Dorset, UK  
BH17 7BA  
Telephone: +44 (0) 1202 606300  
Fax: +44 (0) 1202 606301  
Email: [support.digiplan@parker.com](mailto:support.digiplan@parker.com)  
Internet: <http://www.parker-emd.com>

### Italy

Parker Hannifin  
20092 Cinisello Balsamo  
Milan, Italy via Gounod, 1  
Telephone: +39 02 6601 2478  
Fax: +39 02 6601 2808  
Email: [sales.sbc@parker.com](mailto:sales.sbc@parker.com)  
Internet: <http://www.parker-emd.com>



Technical Support E-mail

[emn\\_support@parker.com](mailto:emn_support@parker.com)

# Table of Contents

<b>User Information</b> .....	<b>2</b>
<b>Table of Contents</b> .....	<b>3</b>
<b>Important Safety Information</b> .....	<b>5</b>
<b>Change Summary</b> .....	<b>6</b>
<b>Overview</b> .....	<b>7</b>
<b>Getting Started</b> .....	<b>8</b>
<b>System Setup</b> .....	<b>9</b>
Cabling Requirements .....	9
<b>Connecting Logic</b> .....	<b>10</b>
<b>Using Logic Voltages Other Than 5 Volts DC</b> .....	<b>11</b>
<b>Connecting to the Parker ACR9000 Controller</b> .....	<b>13</b>
<b>Connecting to the Parker 6K-Series Controller</b> .....	<b>14</b>
<b>Connecting the Motor</b> .....	<b>15</b>
Four-Lead Motors.....	15
Eight-Lead Motors.....	15
<b>Microstepping</b> .....	<b>16</b>
<b>Setting Phase Current</b> .....	<b>17</b>
Setting Motor Phase Current by Formula.....	17
Setting Motor Phase Current by Pictorial.....	18
<b>Idle Current Reduction</b> .....	<b>19</b>
<b>Mounting the Drive</b> .....	<b>19</b>
<b>Connecting the Power Supply</b> .....	<b>20</b>
<b>Self Test</b> .....	<b>21</b>
<b>Choosing a Power Supply</b> .....	<b>21</b>
Voltage.....	21
Current .....	22
<b>Drive Specifications</b> .....	<b>23</b>
Amplifiers .....	23
Inputs .....	23
Physical .....	23
Connectors .....	23
Self Test .....	24
Microstepping Resolution .....	24
CE Certification.....	24
Mechanical Dimensions.....	24
<b>Power Supply Specifications</b> .....	<b>25</b>
Electrical Specifications .....	25
Mechanical Dimensions.....	26



Product Type.....Step Motor Driver OFS350-OSC and OFS350-DRI

The above product complies with the requirements of directives:

- EMC Directive 89/336/EEC;
- Low Voltage Directive 73/23/EEC; and
- CE Marking Directive 93/68/EEC

provided the installation requirements described in this guide are met, and there are no special requirements of the installation and operating environment so that the application may be considered typical.

The above equipment conforms with the protection requirements of Council Directive 89/336/EEC as amended by Directive 92/31/EEC on the approximation of the laws of the Member States relating to Electromagnetic Compatibility when installed, operated and maintained as intended. Also: -The above equipment conforms with the requirements of Council Directive 73/23/EEC (Low Voltage Directive) as amended by Directive 93/68/EEC (CE Marking Directive), when installed, operated, and maintained as intended.

In accordance with IEC 61800-3:1997 (Adjustable speed electrical power drive systems) this product is of the restricted sales distribution class which meets the needs of an industrial environment when installed as directed. However, further measures may need to be taken for use of the product in a domestic environment.

The installation requirements are detailed in the Information supplied with the equipment. The equipment is sold only to competent system builders.

Compliance is demonstrated by the application of the following standards:

- BS EN 61800-3 (1997) including Amendment A11 Adjustable speed electrical Power drive systems Part 3. EMC product standard including specific test methods.
- BS EN 50081-2 (1994) Electromagnetic compatibility—Generic emission standard Part 2. Industrial Environment.
- BS EN 61000-6-2 (1999) Electromagnetic compatibility Part 6-2: Generic Standards – Immunity for industrial environments.
- BS EN 61010-1 (1993) including Amendment A2. Safety requirements for electrical equipment for measurement, control, and laboratory use. Part 1 General Requirements.



**Warning — Risk of damage and/or personal injury**

The OFS350-DRI step motor driver described in this guide contains no user-serviceable parts. Attempting to open the case of any unit, or to replace any internal component, may result in damage to the unit and/or personal injury. This may also void the warranty.

---

# Important Safety Information

---

It is important that motion control equipment is installed and operated in such a way that all applicable safety requirements are met. It is your responsibility as an installer to ensure that you identify the relevant safety standards and comply with them; failure to do so may result in damage to equipment and personal injury. In particular, you should study the contents of this user guide carefully before installing or operating the equipment.

The installation, set up, test, and maintenance procedures given in this user guide should only be carried out by competent personnel trained in the installation of electronic equipment. Such personnel should be aware of the potential electrical and mechanical hazards associated with mains-powered motion control equipment—please see the safety warnings below. The individual or group having overall responsibility for this equipment must ensure that operators are adequately trained.

Under no circumstances will the suppliers of the equipment be liable for any incidental, consequential or special damages of any kind whatsoever, including but not limited to lost profits arising from or in any way connected with the use of the equipment or this guide.



---

**Warning** — High-performance motion control equipment is capable of producing rapid movement and very high forces. Unexpected motion may occur especially during the development of controller programs. **KEEP WELL CLEAR** of any machinery driven by stepper or servo motors. Never touch any part of the equipment while it is in operation.

This product is sold as a motion control component to be installed in a complete system using good engineering practice. Care must be taken to ensure that the product is installed and used in a safe manner according to local safety laws and regulations. In particular, the product must be positioned such that no part is accessible while power may be applied.

This and other information from Parker Hannifin Corporation, its subsidiaries, and authorized distributors provides product or system options for further investigation by users having technical expertise. Before you select or use any product or system, it is important that you analyze all aspects of your application and review the information concerning the product in the current product catalog. The user, through its own analysis and testing, is solely responsible for making the final selection of the system and components and assuring that all performance, safety, and warning requirements of the application are met.

If the equipment is used in any manner that does not conform to the instructions given in this user guide, then the protection provided by the equipment may be impaired.

---

The information in this user guide, including any apparatus, methods, techniques, and concepts described herein, are the proprietary property of Parker Hannifin or its licensors, and may not be copied, disclosed, or used for any purpose not expressly authorized by the owner thereof.

Since Parker Hannifin constantly strives to improve all of its products, we reserve the right to modify equipment and user guides without prior notice. No part of this user guide may be reproduced in any form without the prior consent of Parker Hannifin.

## *Change Summary*

### **Revision B Changes**

This document, 88-029135-01B, supercedes 88-029135-01A.  
Document changes are as follows:

Topic	Description
Enable input	Added Note regarding cautions when using ENABLE input to disable the drive in <a href="#">Connecting Logic</a> section.

# Overview

The OFS350-DRI (3.5 Amp Open Frame Stepper) is a microstepping driver which is operated with an external step and direction controller. The OFS350-DRI has the following features:

- Powerful microstepping amplifier provides high torque and smooth, quiet motion.
- DIP switch provides easy configuration.
- Drives size 11 through 34 frame stepper motors.
- Uses pulse width modulated, MOSFET three-state switching amplifiers.
- Accepts a wide range of DC power supply voltages: 12 – 42 volts DC.
- Phase current adjusts from 0.4 to 3.5 amps peak, selectable with 32 switch settings.
- Inputs are optically isolated.
- Step increments are switch-selectable to resolutions of 1/2, 1/5, 1/10, and 1/64 step (400, 1000, 2000, 12800 steps respectively).
- Automatic 50% idle current reduction lowers motor and drive heating, and is switch selectable.
- Screw terminal connections make wiring easy.
- Compact size: 1.5 x 3 x 4 inches.

The OFS350-DRI is represented in the following block diagram:

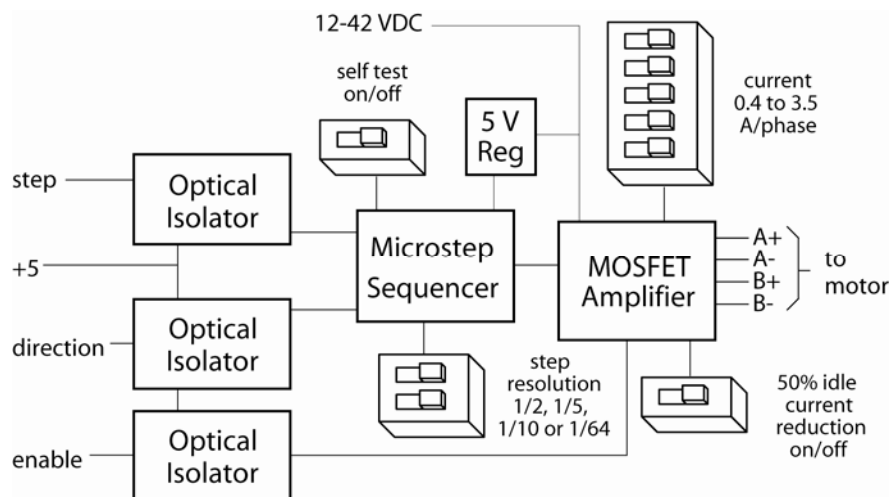

# Getting Started

The OFS350-DRI requires the following for installation:

- A 12 – 42 volt DC power supply for the motor. (See the section *Choosing a Power Supply* on page 21 for recommendations on determining the appropriate power supply for your application.) Parker recommends the STP-32PRK4 power supply, available from Parker.
- A +5 volts DC, 15 mA input to activate the optoisolation circuits. This is provided by most indexers and PLCs. If you don't use 5-volt logic, see the section *Using Logic Voltages Other Than 5 Volts DC* on page 11. The 5V input is provided by Parker's STP-32PRK4 power supply.
- A source of step pulses capable of sinking at least 5 mA, such as Parker's ACR9000 or 6K series controllers.
- A compatible step motor, such as Parker's LV series step motors.
- Appropriate wire or cabling. (See the section *Cabling Requirements* on page 9.)
- A small flat-blade screwdriver for tightening the connectors.

The following drawing shows the connectors and adjustment points for the OFS350-DRI:

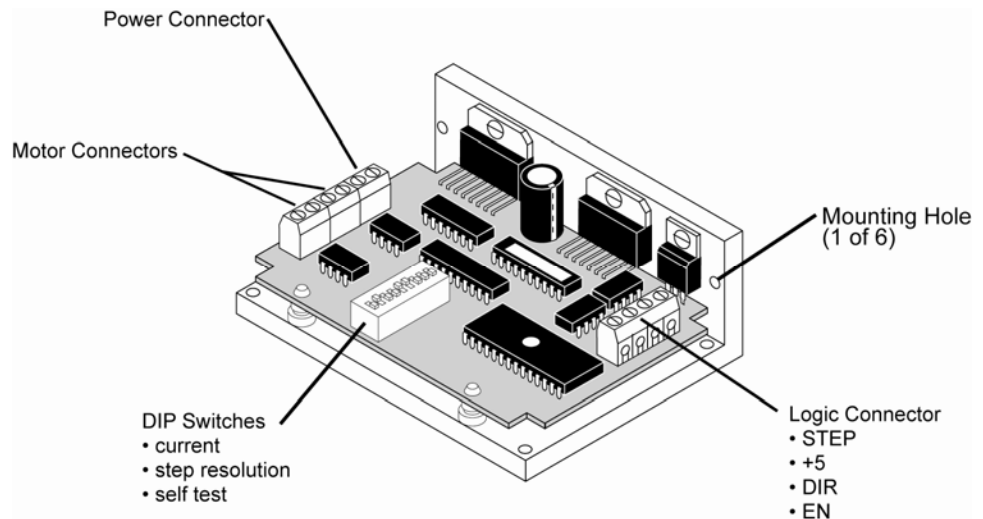



# System Setup

The following block diagram shows the required setup for the OFS350-DRI:

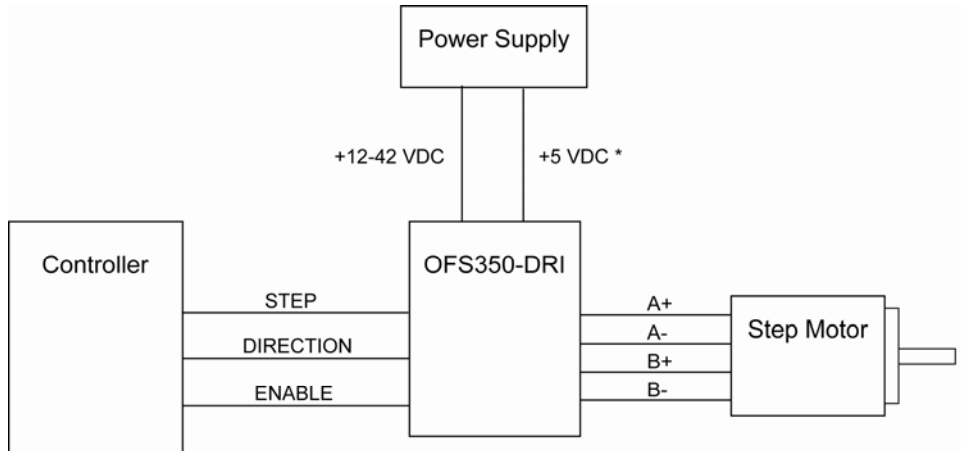

\* NOTE: 5 VDC may be supplied from the power supply or the controller.

## Cabling Requirements

The OFS series of stepper drives require the user to supply cabling for power supply, signal, and motor connections:

- Cabling from the power supply to the OFS drive should use a minimum wire gauge of 20 AWG.
- Motor extension cabling to the OFS drive should use a minimum wire gauge of 20 AWG.
- Signal wiring from the controller to the OFS drive does not carry appreciable amounts of current, and a wire of greater than 28 AWG is recommended. Shielded cabling is recommended to reduce the effects of electromagnetic interference (EMI). The cable shield should be connected to earth ground.

**NOTE:** The smaller the AWG number, the larger the wire and the more current it can carry. For example, 28 AWG is smaller wire than 24 AWG, which is smaller than 20 AWG.

# Connecting Logic

The OFS350-DRI contains optical isolation circuitry to prevent the electrical noise inherent in switching amplifiers from interfering with your circuits. Optical isolation is accomplished by powering the motor driver from a different supply than your circuits. There is no electrical connection between the two: signal communication is achieved by infrared light. When your circuit is in the logic low state (near 0 volts), it is directing electrical current through an LED that is built into the drive. The LED, in turn, produces infrared light which turns on a phototransistor that is wired to the internal control circuitry of the drive. When your circuit is in the logic high state, the LED and phototransistor turn off.

Following is a schematic diagram of the input optoisolation circuit.

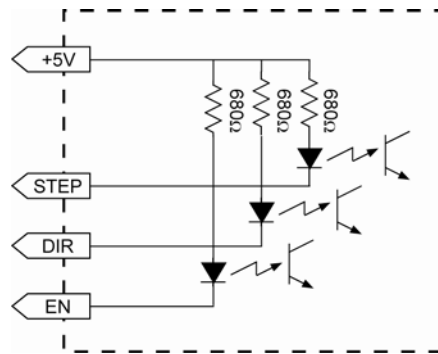

You must apply 5 volts DC to the +5 terminal on the Logic Connector terminal block in order to supply current to the LEDs on the input side of the optoisolators. The maximum current draw is 15 mA total.

Your controlling logic must be capable of sinking at least 5 mA to control each drive input. Most CMOS and open collector TTL devices are directly compatible with this drive. Logic low, or 0, for a given input occurs when that input is pulled to less than 0.8 volts DC. In this state the LED is conducting current. Logic high, or 1, occurs when the input is greater than 4 volts or open.

- ▶ **STEP** tells the driver when to move the motor one step. The drive steps on the rising edge of the pulse. The minimum pulse width is 0.5 microseconds.
- ▶ **DIRECTION** signals which way the motor should turn. The DIRECTION signal should be changed at least 2 microseconds before a step pulse is sent.



### Warning

If you change the state of the direction input and send a step pulse at the same instant, the motor may take a step in the wrong direction.

See the following step table (half-stepping) for more details. Step 0 is the power-up state.

Step	A+	A-	B+	B-
0	open	open	+	-
1	+	-	+	-
2	+	-	open	open
3	+	-	-	+
4	open	open	-	+
5	-	+	-	+
6	-	+	open	open
7	-	+	+	-
8	open	open	+	-

DIR=1 cw (downward arrow)      DIR=0 ccw (upward arrow)

- ▶ **ENABLE** allows the user to turn off the current to the motor by setting this signal to logic 0. The logic circuitry continues to operate so the drive “remembers” the step position even when the amplifiers are disabled. However, the motor may move slightly when the current is removed depending on the exact motor and load characteristics.

**NOTE:** If you have no need to disable the amplifiers, you do not need to connect anything to the ENABLE input.

**NOTE:** When using the ENABLE input to disable the drive, care should be taken on drive shut down to ensure that the voltage powering the ENABLE input is removed after the main drive power. If not, the drive may re-enable and the motor may turn.

## Using Logic Voltages Other Than 5 Volts DC

The OFS350-DRI was designed to be used with 5 volt CMOS and TTL logic signals. To prevent interference between the drive and the controlling logic, the input signals are optically isolated. (See the previous section.) The LEDs require at least 5 milliamps of current to turn on, but cannot withstand more than 20 mA. Because the LEDs themselves only drop about two volts, current limiting resistors must be used on each logic input.

The unit’s design includes current-limiting 680  $\Omega$  resistors, so if your logic voltage is 5 volts, you do not need to add external resistors.

If your logic voltage is higher than 5 volts, you must add a resistor (1/4 watt or larger) in series with each signal that you use (STEP, DIR, and EN). The recommended wiring diagram is shown below.

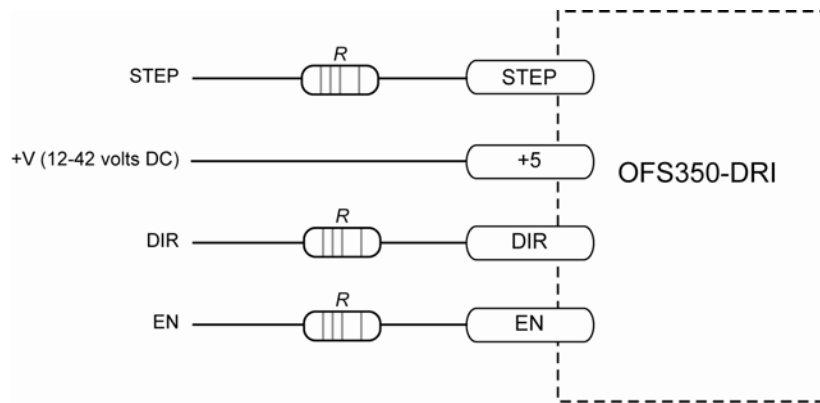

**Warning** — Be careful not to reverse the wiring—this will cause damage to the LEDs and render the drive inoperable. Check your wiring carefully before turning on the power supply.

NOTE: The DIR signal is only required for bidirectional motion. The EN signal is only required to shut off motor current. Both inputs can be left open if not needed.

The following table lists the appropriate resistor value to use for a given power supply voltage.

External Resistors (1/4 watt or larger)					
Supply Voltage	R (Ohms)	Supply Voltage	R (Ohms)	Supply Voltage	R (Ohms)
12	1200	21	3000	30	4700
15	1800	24	3600	33	5100
18	2400	27	4200	35	5600

# Connecting to the Parker ACR9000 Controller

The OFS350-DRI can be controlled by the ACR9000 or ACR9030. See the following figure for connecting the unit to the controller using cable 71-022344-XX.

\* Note: Duplicate wire colors are present in this cable. See chart below for wire color differentiation.

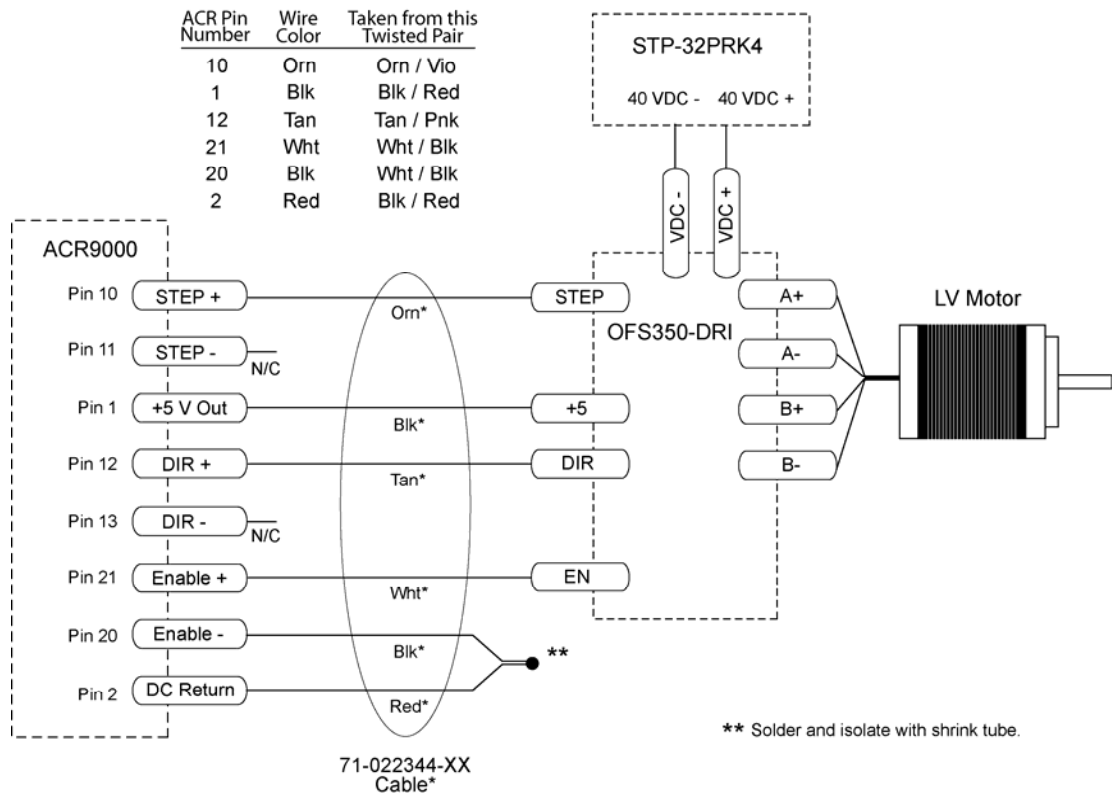

See the section *Cabling Requirements* on page 9 for cable sizes.

See the section *Connecting the Motor* on page 15 for LV motor wire color codes.

**NOTE:** There is no fault output on the OFS350 drive. When using this drive with the ACR9000 controller, set the Disable Drive Fault Response flag by setting Bit 8452 to 1.

# Connecting to the Parker 6K-Series Controller

The OFS350-DRI can be controlled by any of the 6K series controllers. See the following figure for connecting the unit to a 6K.

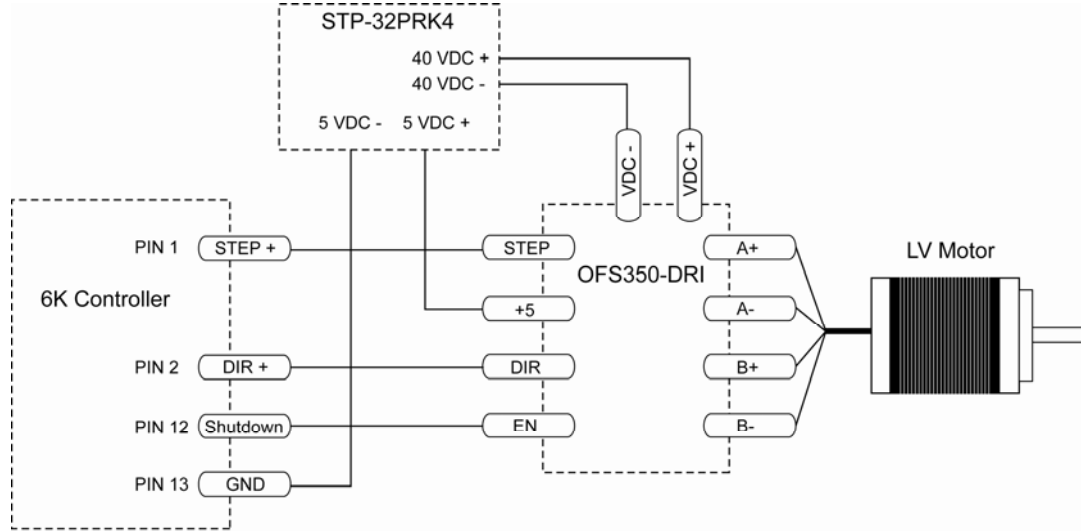

See the section *Cabling Requirements* on page 9 for cable sizes.

See the section *Connecting the Motor* on page 15 for LV motor wire color codes.

# Connecting the Motor

Following are several ways to connect your motor to the OFS350-DRI.



**Warning** — When connecting the motor to the driver, be sure that the motor power supply is off. Secure any unused motor leads so that they cannot short out to anything. Never disconnect the motor while the drive is powered up. Never connect motor leads to ground or to a power supply!

## Four-Lead Motors

Four-lead motors can be connected in only one way. The color codes shown are for the Parker LV11 series motors. Other four-lead motor color codes may vary.

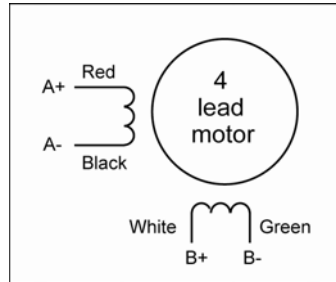

## Eight-Lead Motors

Eight-lead motors can be connected in two ways, series or parallel. Series operation gives you more torque at low speeds and less torque at high speeds. The wiring diagrams for eight-lead motors are shown below. The color codes are for Parker's LV series motors, size 17 – 34. Other motor color codes may vary.

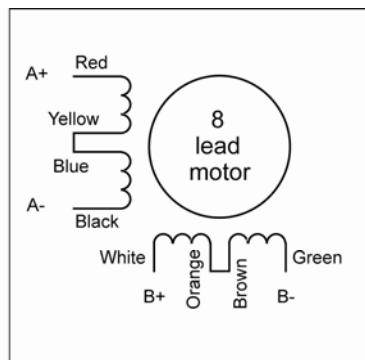

8 Leads - Series Connected

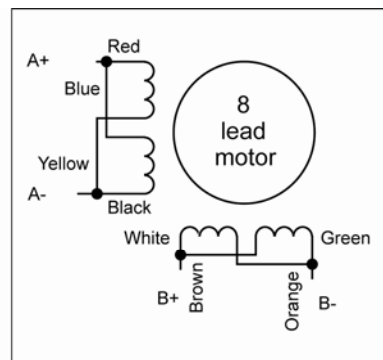

8 Leads - Parallel Connected

Using solder, link Yellow and Blue leads, and link Orange and Brown leads; electrically isolate with shrink tube.

# Microstepping

Most step motor drives offer a choice between full step and half step resolutions. In most full step drives, both motor phases are used all the time. Half stepping divides each step into two smaller steps by alternating between both phases on and one phase on. The OFS350-DRI and other microstepping drives precisely control the amount of current in each phase at each step position as a means of electronically subdividing the steps even further.

The OFS350-DRI offers a choice of half step and three (3) microstep resolutions. The highest setting divides each full step into 64 microsteps, providing 12,800 steps per revolution when using a 1.8-degree motor.

In addition to providing precise positioning and smooth motion, microstep drives can be used to provide motion in convenient units. When the drive is set to 2000 steps/rev (1/10 step) and used with a 5-pitch lead screw, you get .0001 inches/step.

To set the step resolution, locate the DIP switch on the unit. Next to switches 2 and 3 are labels on the printed circuit board. Each switch has two markings on each end:

- ▶ Switch 2 is labeled 1/2 and 1/10 on one end, and 1/5 and 1/64 on the other end.
- ▶ Switch 3 is labeled 1/5 and 1/2 on one end, and 1/10 and 1/64 on the other end.

To set the drive for a resolution, set both switches toward the proper label. For example, if you want 1/10 step, push Switch 2 toward the 1/10 label (to the left), and push Switch 3 toward the 1/10 label (to the right).

The figure below shows the four possible microstepping settings.

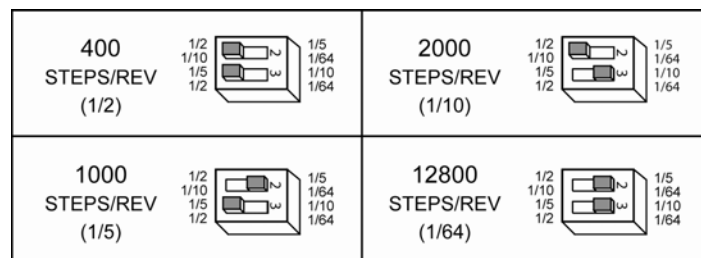



# Setting Phase Current

Before turning on the power supply the first time, set the DIP switches for the proper motor phase current. (You can determine the DIP switch settings either by formula or by using the Current Setting Table in this manual.) You may need to use a very small screwdriver for this task. See the table below for a list of Parker-recommended motors to find the current value of your motor.

## Recommended Motors Table

The following table lists Parker Hannifin's motor recommendations for use with the OFS350-DRI step motor drive. See the last column for current values.

Recommended Motors			
Motor P/N	Winding	Max. Running Torque (oz.-in.)	Current (Amps Peak)
LV111	4-Lead	4	1.3
LV113	4-Lead	7	1.3
LV171	Series Parallel	39	1.1
		40	2.2
LV173	Series Parallel	60	1.2
		60	2.5
LV231	Series Parallel	55	2.8
		29	3.5
LV233	Series Parallel	164	3.5
		71	3.5
LV341	Series Parallel	410	3.5
		255	3.5

## Setting Motor Phase Current by Formula

Locate the DIP switches on the OFS350-DRI. Five of the switches are labeled with current values. There is always a base of 0.4 A, and you must add to that as necessary by setting the current switches. (Each switch controls the amount of current, in amperes (A), that its label indicates.)

**Example:** To set the driver for 2.2 amps per phase, set the 1.6 switch and the 0.2 switch by sliding them toward the labels. These two values are added to the base of 0.4 to make the required 2.2 amps.



$$(2.2 = 0.4 + 1.6 + 0.2)$$

## Setting Motor Phase Current by Pictorial

Alternatively, you can set the motor phase current on the DIP switches according to the illustrations below. Locate the desired current/phase value and set the switches as shown in the corresponding pictorial.

<p><b>0.4</b> Amps/ Phase</p>	<p><b>1.2</b> Amps/ Phase</p>	<p><b>2.0</b> Amps/ Phase</p>	<p><b>2.8</b> Amps/ Phase</p>
<p><b>0.5</b> Amps/ Phase</p>	<p><b>1.3</b> Amps/ Phase</p>	<p><b>2.1</b> Amps/ Phase</p>	<p><b>2.9</b> Amps/ Phase</p>
<p><b>0.6</b> Amps/ Phase</p>	<p><b>1.4</b> Amps/ Phase</p>	<p><b>2.2</b> Amps/ Phase</p>	<p><b>3.0</b> Amps/ Phase</p>
<p><b>0.7</b> Amps/ Phase</p>	<p><b>1.5</b> Amps/ Phase</p>	<p><b>2.3</b> Amps/ Phase</p>	<p><b>3.1</b> Amps/ Phase</p>
<p><b>0.8</b> Amps/ Phase</p>	<p><b>1.6</b> Amps/ Phase</p>	<p><b>2.4</b> Amps/ Phase</p>	<p><b>3.2</b> Amps/ Phase</p>
<p><b>0.9</b> Amps/ Phase</p>	<p><b>1.7</b> Amps/ Phase</p>	<p><b>2.5</b> Amps/ Phase</p>	<p><b>3.3</b> Amps/ Phase</p>
<p><b>1.0</b> Amps/ Phase</p>	<p><b>1.8</b> Amps/ Phase</p>	<p><b>2.6</b> Amps/ Phase</p>	<p><b>3.4</b> Amps/ Phase</p>
<p><b>1.1</b> Amps/ Phase</p>	<p><b>1.9</b> Amps/ Phase</p>	<p><b>2.7</b> Amps/ Phase</p>	<p><b>3.5</b> Amps/ Phase</p>

## Idle Current Reduction

The OFS350-DRI is equipped with a feature that automatically reduces the motor current by 50% anytime the motor is not moving. This reduces drive heating by about 50% and lowers motor heating by 75%. This feature can be disabled if desired so that full current is maintained at all times, which is useful when a high holding torque is required.

To minimize motor and drive heating, we highly recommend that you enable the idle current reduction feature unless your application strictly forbids it.

Idle current reduction is enabled by sliding switch #4 toward the 50% IDLE label. Sliding the switch away from the 50% IDLE label disables the reduction feature. Both switch selections are shown here.



## Mounting the Drive

The amplifiers on the OFS350-DRI generate heat. Operating the unit continuously at maximum power requires use of a heat sinking surface with a thermal constant of no more than 4°C/watt. Often, the metal enclosure of your system will make an effective heat sink. (If you are running the drive at 1 amp or below, you might not need a heatsink.)



**Warning** — Never use your drive where there is no air flow or where other devices cause the surrounding air to be more than 70°C. Don't put the drive where it can get wet or where metal particles can get on it.

The OFS350-DRI drive can be mounted on the wide or the narrow side of the chassis. If you mount the drive on the wide side, use #4 screws through the four corner holes. For narrow side mounting applications, use #4 screws in the two side holes. See the drawings below.

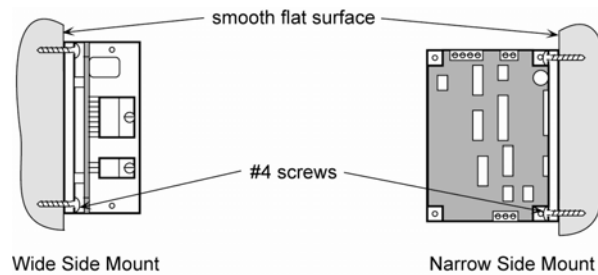
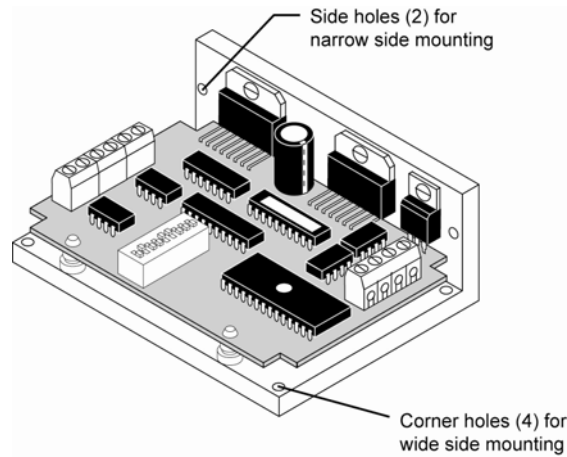

## Connecting the Power Supply

Parker recommends the STP-32PRK4 power supply, available from Parker.

If your power supply does not have a fuse on the output or some kind of short circuit current-limiting feature, you must put a 4 amp fast-acting fuse between the drive and power supply. Install the fuse on the positive (+) power supply lead. Use no smaller than 20 gauge wire.

**NOTE:** The STP-32PRK4 power supply is internally fused. No additional fuses are required when connecting to the OFS350 drive.

Connect the DC power supply positive (+) terminal to the driver terminal labeled **+VDC**. Connect the DC power supply negative (-) terminal to the driver terminal labeled **VDC-**. See the drawing below.



**Warning** — Be careful not to reverse the wires. Reversing connections will destroy the driver and void the warranty.

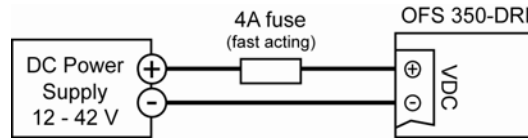

## Self Test

The OFS350-DRI includes a self-test feature for troubleshooting. If you are unsure about the motor or signal connections to the drive, or if the OFS350-DRI is not responding to your step pulses, you can turn on the self test.

To activate the self test, slide DIP switch #1 toward the TEST label. The drive will slowly rotate the motor 1/2 revolution forward, then 1/2 revolution backward. The pattern repeats until you slide the switch away from the TEST label.

The OFS350-DRI always uses half-step mode during the self test, no matter how switches 2 and 3 are set. The self test ignores the STEP and DIRECTION inputs while operating. The ENABLE input continues to function normally.



Self Test is ON



Self Test is OFF

## Choosing a Power Supply

This section is included to help you select a power supply that is suitable for your application. (Parker recommends the STP-32PRK4 power supply, available from Parker.)

### Voltage

Chopper drives work by switching the voltage to the motor terminals ON and OFF while monitoring current to achieve a precise level of phase current. To do this efficiently and silently, it is important to have a power supply with a voltage rating at least five times that of the motor. Depending on how fast you want to run the motor, you may need even more voltage. More voltage is better, with the

upper limit being the maximum voltage rating of the drive itself (42 volts, including ripple).

If you choose an unregulated power supply, do not exceed 35 VDC (as unregulated supplies are rated at full load current). At lesser loads, such as when the motor is not moving, the actual voltage can be up to 1.4 times the voltage listed on the power supply label.

**NOTE:** Parker rates the STP-32PRK4 power supply at no load conditions (contrary to most other unregulated supply ratings) for consistency with older Parker power supply ratings. The STP-32PRK4 outputs 40VDC at no load, and 32VDC fully loaded.

## Current

The maximum supply current needed is the sum of the two phase currents. However, you will generally need a lot less than that, depending on the motor type, voltage, speed, and load conditions. That's because the OFS350-DRI uses switching amplifiers, converting a high voltage and low current into lower voltage and higher current. The more the power supply voltage exceeds the motor voltage, the less current you will need from the power supply.

Recommended Selection Procedure:

1. If you plan to use only a few drives, use a power supply with at least twice the rated phase current of the motor.
2. If you are designing for mass production and must minimize cost, get one power supply with more than twice the rated current of the motor. Install the motor in the application and monitor the current coming out of the power supply and into the drive at various motor loads. This will tell you how much current you really need so you can design in a lower cost power supply.

If you plan to use a regulated power supply you may encounter a problem with current foldback. When you first power up your drive, the full current of both motor phases will be drawn for a few milliseconds while the stator field is being established. After that, the amplifiers start chopping and much less current is drawn from the power supply. If your power supply thinks this initial surge is a short circuit it may "foldback" to a lower voltage. With many foldback schemes, the voltage returns to normal only after the first motor step and is fine thereafter. In that sense, unregulated power supplies are better. They are also less expensive.

---

# Drive Specifications

---

Following are technical specifications for the OFS350-DRI.

## Amplifiers

Dual, bipolar MOSFET H-bridge, pulse-width modulated three-state switching at 20 kHz.

Input voltage is 12 – 42 VDC.

Output current is 0.4 – 3.5 amps peak / phase, switch selectable in 0.1 amp increments.

Maximum output power is 122 Watts.

Automatic idle current reduction (switch selectable) reduces current to 50% of setting after one second.

Minimum motor inductance is 1mH.

## Inputs

Step, direction, enable, and a +5V optically isolated logic input.

Current sink requirement is 5 mA/signal, NPN input type.

The motor steps on the rising edge of the step input, which is a 0.5  $\mu$ sec minimum pulse width and a 2  $\mu$ sec minimum setup time for direction signal.

## Physical

Mounted on a 1/4-inch thick, black, anodized aluminum heat-transfer chassis.

Power on LED is red.

Ambient temperature range is 0 – 70°C.

## Connectors

European style screw terminal blocks; maximum wire size is 18 AWG.

Motor connectors: 4 terminals (A+, A-, B+, B-)

Signal input: 4 terminals (+5, STEP, DIR, EN)

DC Input: 2 terminals (V+, V-)

## Self Test

Switch-selectable, rotates motor 1/2 revolution each direction at 100 steps/second (half-step mode).

## Microstepping Resolution

Four switch-selectable step resolutions with 1.8-degree motor:

- ▶ 1/2 step (400 steps/rev)
- ▶ 1/5 step (1000 steps/rev)
- ▶ 1/10 step (2000 steps/rev)
- ▶ 1/64 step (12,800 steps/rev)

## CE Certification

Complies with EN55011A and EN50082-1 (1992).

## Mechanical Dimensions

Drive dimensions are 1.5 x 3.0 x 4.0 inches overall.

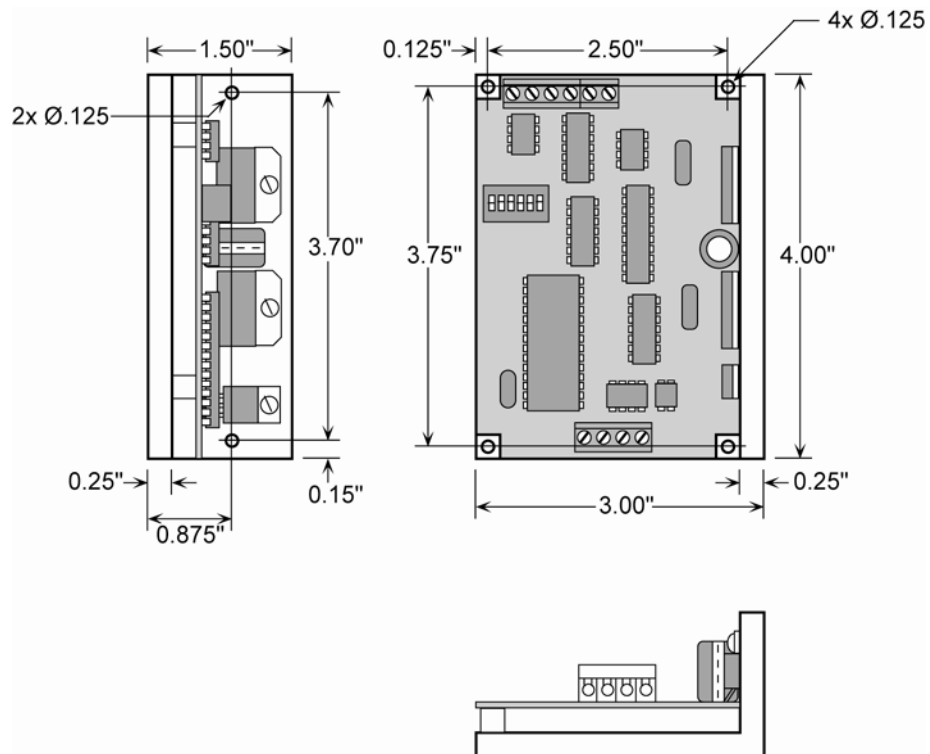



# Power Supply Specifications

Following are technical specifications for the STP-32PRK4 power supply.

## Electrical Specifications

Feature	Specification
Input Power	120/240 VAC, switch selectable
Input Power Tolerance	±10%
Inrush Current	12A at 120V, 15A at 240V
Output Power No Load Full Load (4A) 5V Logic	40 VDC 35 VDC 5 VDC ±5% at 500mA
Storage Temperature	-55°C to +85°C
Operating Temperature	0 to 50°C
Humidity	95%, non-condensing relative humidity
Connections	Screw Terminals
Cooling	Natural convection; allow adequate airflow
Mounting	Use four #8 or #10 screws for mounting
Agency Approvals	UL, CSA, CE

# Mechanical Dimensions

Power supply dimensions are 7.0 x 4.0 x 3.64 overall.

